

TRULINK™

TORQUE MONITOR™

We're Breaking New Ground with the All New TruLink Torque Monitor!

A revolutionary new approach to collecting installation data associated with helical pier projects.



TRULINK™ PIN:

Torque is measured at two points within the connection pin located between the anchor drive attachment and the prime mover. The TruLink™ pin simply replaces the OEM pin ensuring that no additional weight or height is added to the installation equipment.

*Patent Pending
Torque Sensing Capability*

Isolates Torque Values Only

**Provides the Productivity and Accuracy
You Deserve on the Jobsite!**

ORDER TODAY for APRIL DELIVERY!

 **PENGO®**

TURNING CHALLENGES INTO SOLUTIONS!

PENGOATTACHMENTS.COM
800.599.0211 | Fax 800.915.6904

TRULINK

TORQUE MONITOR™

The TruLink™ Torque Monitor system offers true torque readings that deliver a high degree of accuracy (+/- 2%) while providing the operator with real time data. TruLink™ records actual torque being applied to the helical pile, the installation angle and the depth.

Unlike other torque monitoring systems available, TruLink isolates torque values only. Downward and side load forces are omitted ensuring the data is clean.

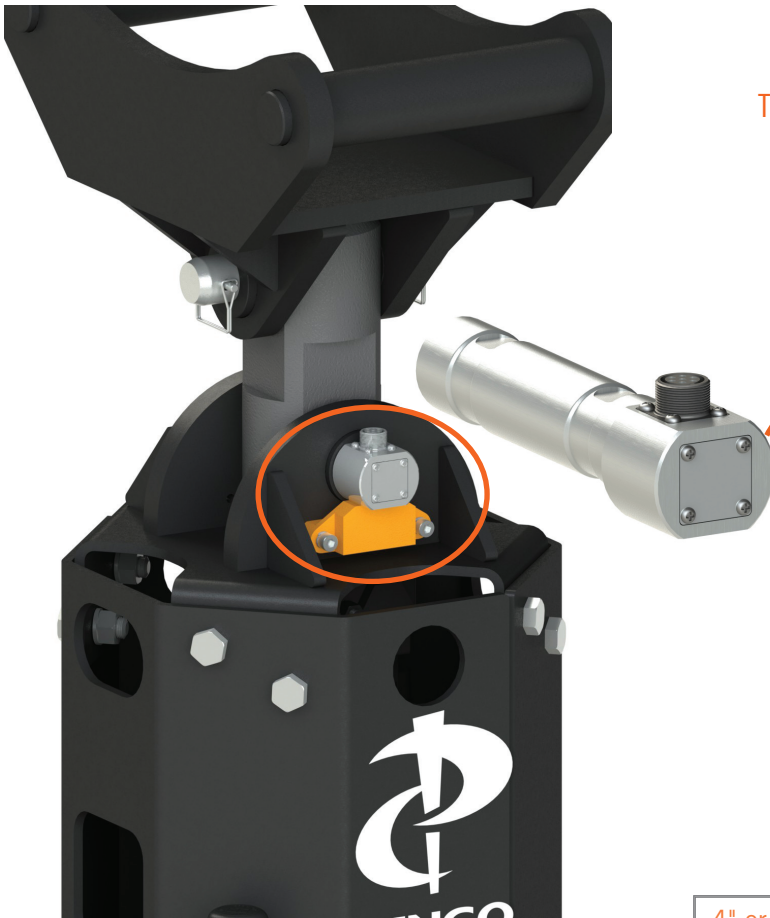

- Replaces Connection Pin
 - No Added Weight or Height or Loss of Stroke
- Built-in Inclinometer Allows Operator to Maintain a Consistent Angle of Insertion
- All Data is Recorded Within the Display
 - No Laptop Required to Extract Data
- Downward (perpendicular) Force is Omitted with Patent Pending Technology
 - Isolating Torque Values
- Strain Gage Technology
 - Not "Inferred" or Calculated as With Hydraulic Systems
- Hard Wired Connection
 - Eliminates Interference and Signal Issues Encountered with Wireless Systems
- Ability to Chart and Record Depth for Each Pile



- 4" or 8" Easy to Read, Touch Screen Display
- Displays Time/Date, Torque, Depth and Pile Number
- Easily Mounts Inside Operators Cab
- ip67 Display Housing
 - Rugged, Weatherproof and Shock-Resistant
- Simple Power Supply
 - Adapter uses Auxiliary Power Port, Cigarette Lighter

DESCRIPTION	Screen Size	Pin Dia.	Max Torq	PART NO.
TL4-C1	4"	45mm	22500 (ft/lb)	615000
TL4-C2	4"	45mm	69126 (ft/lb)	615001
TL8-C1	8"	45mm	22500 (ft/lb)	615002
TL8-C2	8"	75mm	69126 (ft/lb)	615003
TL8-C3	8"	3.967"	110418 (ft/lb)	615004
TL8-C4	8"	4.5"	211790 (ft/lb)	615005